

Installing the Balanced Body® Rialto with Tower Konnector™

The Konnector is compatible with Balanced Body Rialto Reformers with tower ONLY. If you aren't sure whether this system will work with your equipment, please contact Balanced Body at 1-800-PILATES (US and Canada), or +1-916-388-2838 (all other countries).

To view the installation podcast, please visit www.pilates.com/instructions

TOOLS REQUIRED (NOT INCLUDED):

- » Power Drill
- » Phillips Head screw driver

PARTS LIST (INCLUDED):

ITEM	PART NO.	QTY
Konnector Rope	210-054	1
Tri-Loops (Grey)	210-061	1 pr
Tri-Loops (Black) with pulleys	210-060	1 pr
Twist lock flanged post ASM	950-264	1 pr
Under carriage ASM	624-002	2
Pulley Assembly for Wood	620-083	2
Shoulder brackets	607-546	2
Pulley Block Assembly	624-003	2
Wood Template	607-542	1
#10 x 5/8 Phillips Pan Head Screw	GEN9143	4
1/4-20 x 1/2 Flat head screws black	GEN6771	4
1/4" Flat Washer	GEN9204	6
1/4-20 Hex Nut	GEN9056	6
5/16" Drill bit	TOL1059	1
3/32" (2.5 mm) Allen wrench	TOL1605	1
5/32" Allen wrench	GEN9282	1
7/32" Allen wrench	TOL1358	1
7/16" Wrench	616-113	1

WARNING: Using the existing shoulder posts with a Konnector system can cause the loops to fall off the posts during use which may cause injury.

REMOVE ROPES, SHOULDER BRACKETS AND PADS

1. Remove the ropes and loops from your Reformer, they are no longer needed.
2. Unthread each knob from the shoulder rest bracket by hand and completely remove them from the shoulder rest bracket. Remove the shoulder rest bracket from the carriage. Repeat on the other side.
3. Using the provided small Allen wrench, remove the four flat head screws from each shoulder bracket as shown in Figure A. Keep these screws, repeat on the other side.

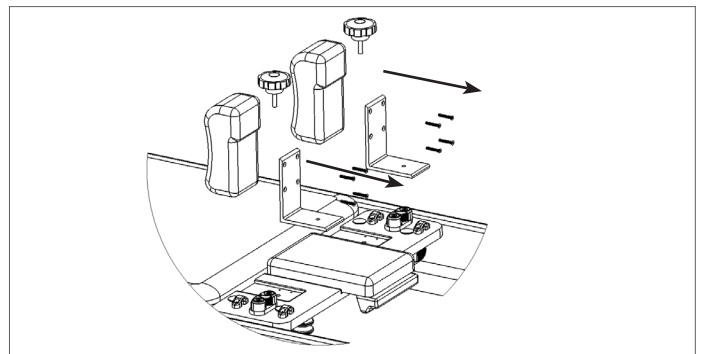
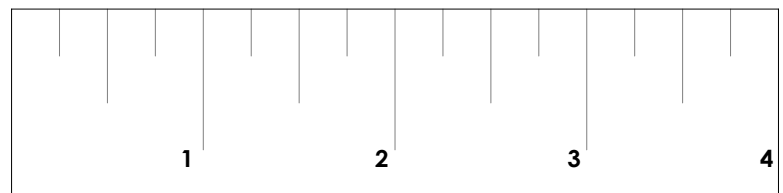

Figure A



WARNING: If you are only using some of the loops, the unused loops MUST be stored on the flanged shoulder posts.

INSTALL SHOULDER BRACKETS & PADS

4. Install the new shoulder brackets that have (2) threaded holes, screw the shoulder pads using the removed screws. Install the screws in the same holes in the same pad as they were removed. See Figure B repeat for other side.

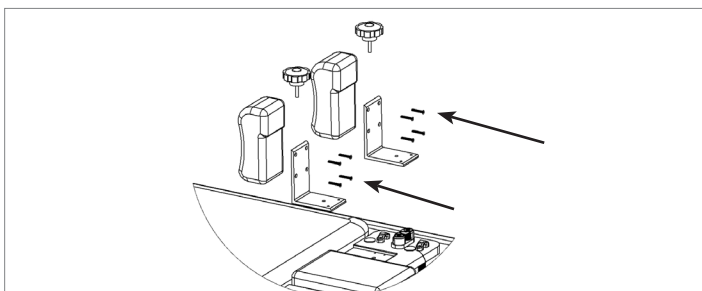

Figure B

5. Install the flanged post and adapter plate assembly plates to the shoulder brackets using the four 1/4-20 flat head screws. See Figure C.

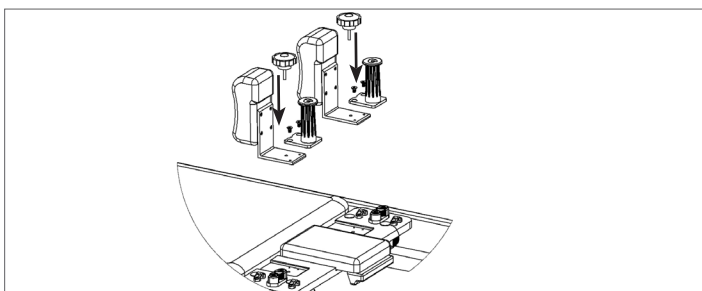

Figure C

INSTALL UNDER CARRIAGE PULLEYS

6. Unhook all of the springs from the springbar. Lift the carriage out of the frame, turn it upside down, and rest it across the Reformer frame with the underside facing up.
7. Remove the four screws on the bracket plates on the bottom of the carriage and remove brackets. Keep these screws. See Figure D. Repeat for other bracket.

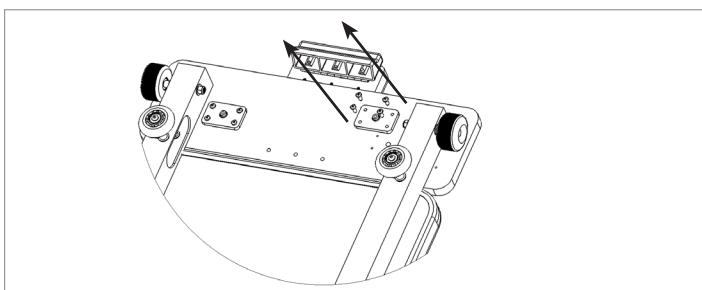

Figure D

8. Install the under carriage mounts, make sure the pulleys point toward the headrest. Using the removed screws install the under carriage brackets as shown in Figure E. Make sure to align the center hole in plate with wood hole. Use two additional #10 wood screws provided in the kit to finish securing the bracket in place. Repeat for other side.

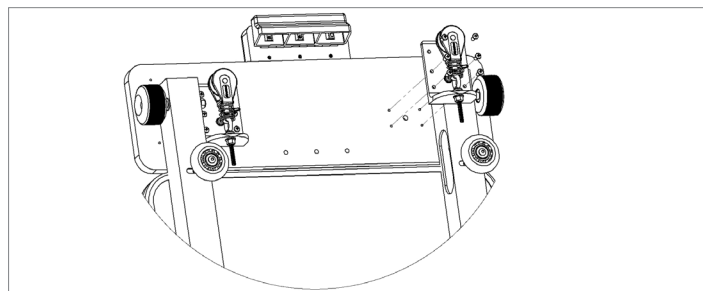

Figure E

9. Turn the carriage back over onto its wheels and place it on the rails with the headrest toward the riser.
10. Make sure the springbar is in the position closest to the foot end of the reformer ("first gear"). Attach at least one red spring to keep the carriage in place.
11. Install the shoulder rests back onto the carriage by inserting the bracket into the cutout in the wood base. Align the hole in bracket with hole in the wood and use the knob to secure by rotating it clockwise. Repeat on the other shoulder bracket.

INSTALL TOWER PULLEYS

12. Remove the current pulleys that are mounted on your tower near the bottom, using the provided biggest 7/32" Allen wrench. See Figure F. Keep the bolts and outside washers, you will reuse these. The washer and block spacer on the inside of the tower will not be used.

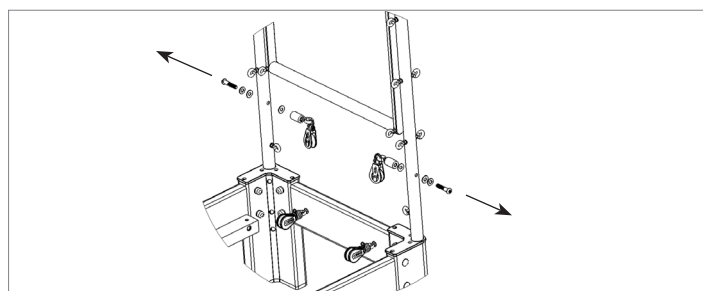

Figure F

13. Install the new pulley blocks with the pulleys as shown in Figure G. Order of items: bolt then removed metal washer, (2) provided thick 3/8" washers, then removed black plastic.

Note: When properly installed the eye bolt facing the carriage is higher than the eyebolt on the end of the block. Repeat on the other side.

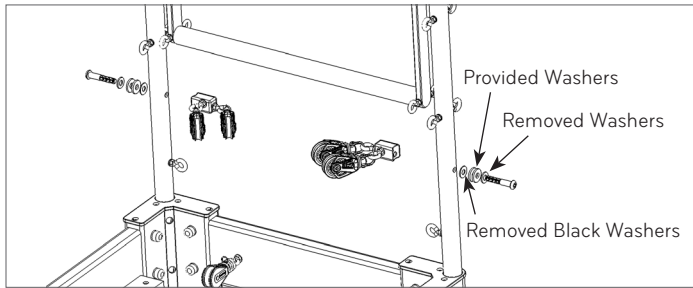

Figure G

INSTALLING LOWER MOUNT PULLIES

14. Using the provided wood template and drill bit you will drill into the wood cross member at the head end. Hold the wood template on the outside of the wood piece, flush with the bottom of the wood and up against the left leg. The hole in the wood template will be in the upper right corner of the template. See Figure H. Hold the template firmly and drill through the cross member. Flip the wood template over and hold it up against the right leg and flush with the bottom of the cross member. The hole should be in the upper left position shown in Figure H. Drill through the cross member holding the template in this position. You can also tape the template into place if hard to hold. You can also hold up the template and use a pencil to mark the hole on the wood. Then remove the template to drill the wood.

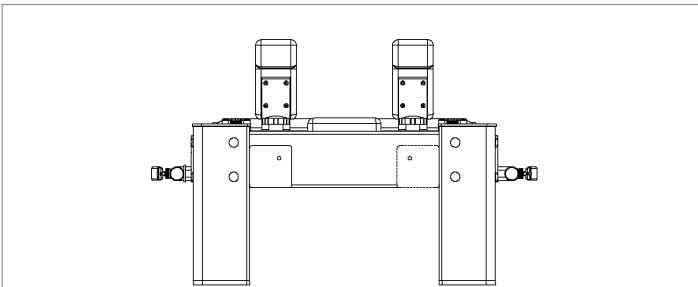

Figure H

15. Install the two provided pulleys into the drilled holes in the head end cross member using two flat washer, two hex nuts pulley. See Figure I for the order of the hardware, washers are up against the wood. Repeat this process for the other pulley.

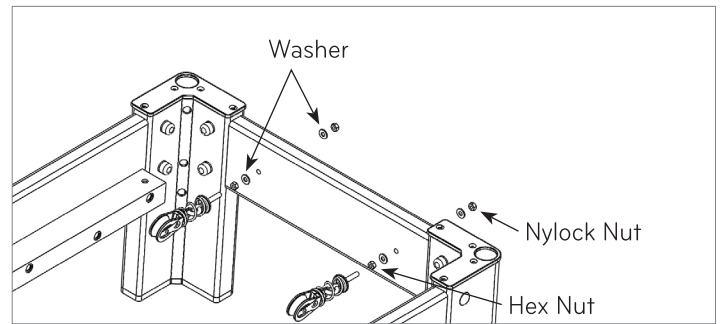

Figure I

INSTALL ROPE AND LOOPS

16. Place the black loops with pulleys on the shoulder posts Figure J.

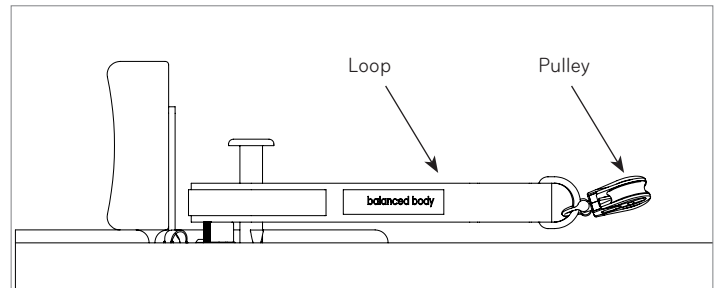

Figure J

17. Thread one end of the rope through both pulleys under the carriage and pull the ends evenly toward the tower. Figure K.

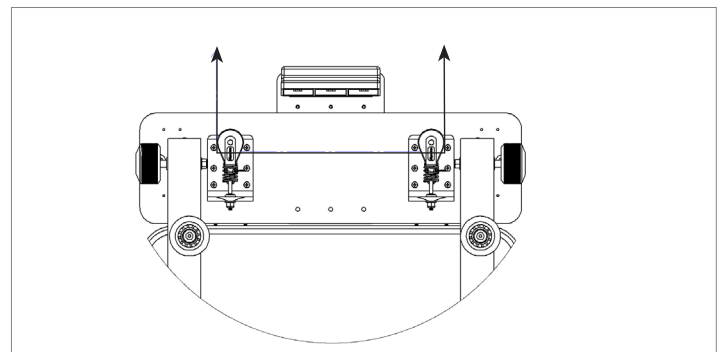

Figure K

18. Take one end of the rope and thread up through the lowest pulley on the head end cross member. Continue threading the rope up through the upper, inner pulley on the tower and pull toward the carriage Figure L.

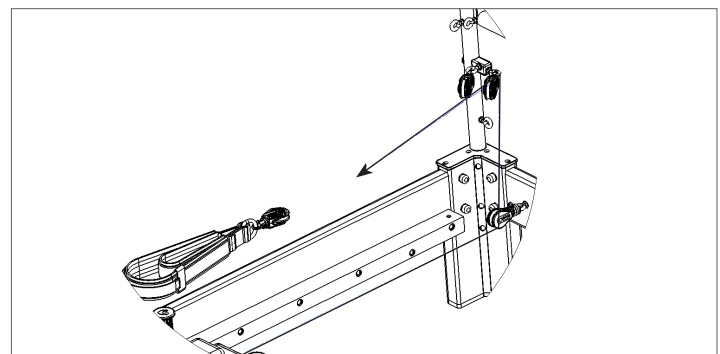

Figure L

19. Thread the rope through the pulley attached to the black Tri-Loop with pulley on the same side of the Reformer as the pulley block and pull back toward the tower. Figure M.

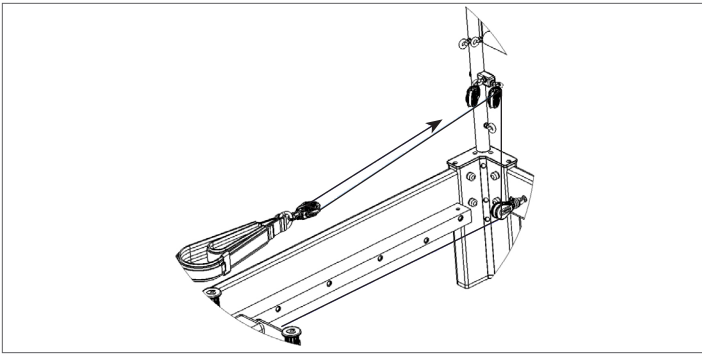

Figure M

20. Thread the rope through the upper, outer pulley on the pulley block and pull back toward the carriage. Figure N. See Figure O for a detailed view of the tower pulley rope routing.

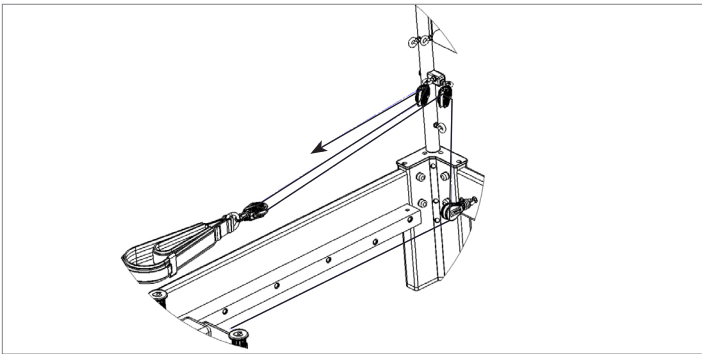

Figure N

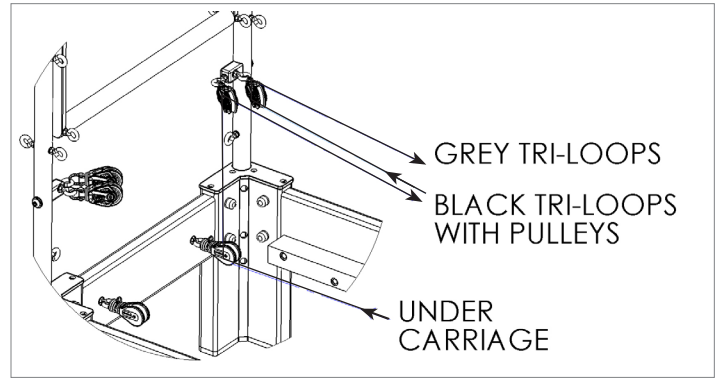

Figure O

21. Using a Soft-Touch connection Figure P, secure each end of the rope to a grey Tri-Loop on the same side of the Reformer as the riser.

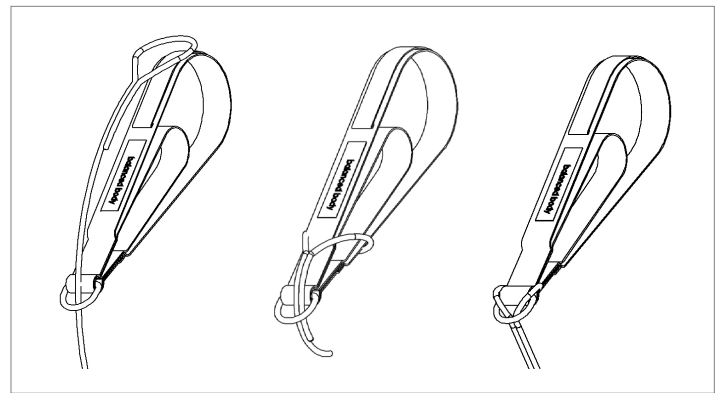

Figure P

22. Repeat steps 18-21 for the other side of the Reformer.

IMPORTANT SAFETY NOTE: Use of the Konnector system in a manner for which it is not intended may result in equipment damage and/or injury to the user. Intense cardio work utilizing jarring movements may overload the system. Balanced Body is not responsible for injuries caused by equipment misuse.

Questions? Call Balanced Body Technical Support at 1-800-PILATES (US and Canada), or +1-916-388-2838 (all other countries).

WARNING: Using the existing shoulder posts with a Konnector system can cause the loops to fall off the posts during use which may cause serious injury.