

Installing the Balanced Body® Allegro 1B with Riser Konnector™

The Konnector is compatible with Balanced Body Allegro Reformers with removable shoulder rests with Twist Lock posts ONLY. If you aren't sure whether this system will work with your equipment, please contact Balanced Body at 1-800-PILATES (US and Canada), or +1-916-388-2838 (all other countries).

To view the installation podcast, please visit www.pilates.com/instructions

PARTS LIST (INCLUDED):

ITEM	PART NO.	QTY
Konnector Rope	210-073	1
Tri-Loops (Grey)	210-061	2
Tri-Loops (Black) with pulleys	210-060	2
Pulley Block Riser Assembly	624-005	2
Lower Mount Allegro Assembly	624-006	2
Under Carriage Mount Assembly	624-004	2
Twist Lock Flanged Cap	616-401	2
1/4"-20x4.25 Socket Head Screws	GEN9575	2
1/4-20 Nylock nut	GEN9021	2
1/4" Flat Washer	GEN9305	4
5/32" Allen wrench	GEN9282	1
3/16" Allen wrench	GEN9280	1
7/16" Wrench	616-113	1
Spacer, Black, 1.5" Diameter**	ALL0516	4

** "If your machine has legs disregard these spacers. If you machine has rubber feet, unscrew each foot. Install the spacer on top of the threaded rubber foot. Screw the foot/spacer assembly back on machine so spacer is between the machine and rubber foot.

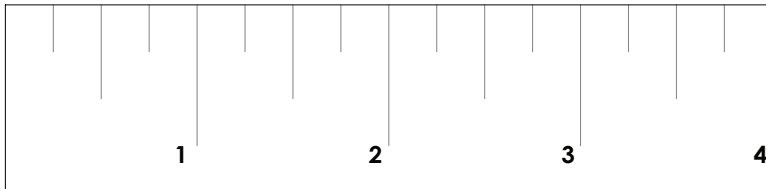

WARNING: Using the existing shoulder posts with a Konnector system can cause the loops to fall off the posts during use which may cause injury.

REMOVE ROPES, POST AND SHOULDER BRACKETS

1. Remove the rope from the cam cleats, carriage and pulleys. They are no longer needed.
2. Unthread each post from the shoulder rest bracket by hand and completely remove them from the shoulder rest bracket. You will no longer need them. Remove the shoulder rest bracket from the carriage. Repeat on the other side.
3. Using the provided Allen key and 7/16" wrench, remove the four nuts and washers from the bolts as shown in Figure A.

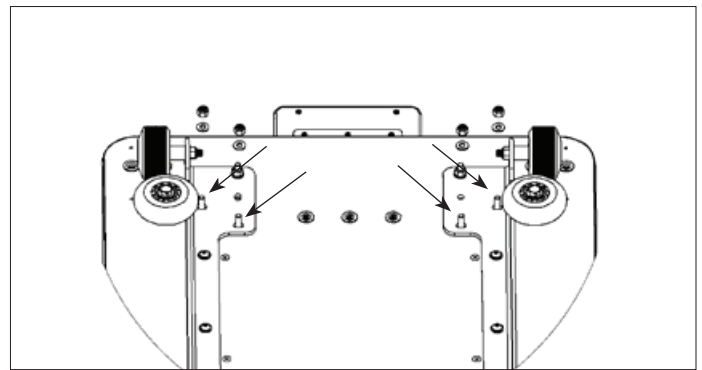

Figure A

WARNING: If you are only using some of the loops, the unused loops MUST be stored on the flanged shoulder posts.

INSTALL THE CARRIAGE PULLEY BRACKETS

4. Bolt the two carriage pulley brackets to the underside of the carriage using existing hardware and nuts just removed. Make sure the pulleys are facing towards the headrest as in Figure B. Tighten nuts securely. If the bolts do not go into the Nylon of nut, it is okay to remove the washers.

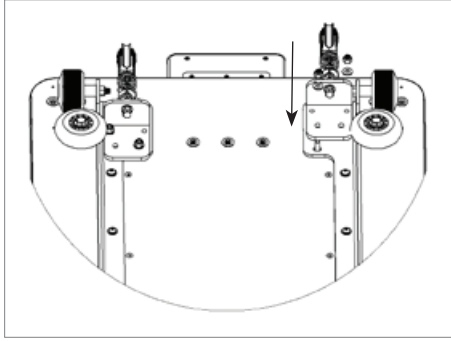

Figure B

5. Install the shoulder rests back onto the carriage by sliding them into the slots and away from the carriage pad.
6. Install new flanged shoulder posts onto the protruding threads of the shoulder rests. Turn the flanged shoulder posts clockwise to tighten. Hand tighten so the shoulder rest does not move. Repeat on the other side. See Figure C.

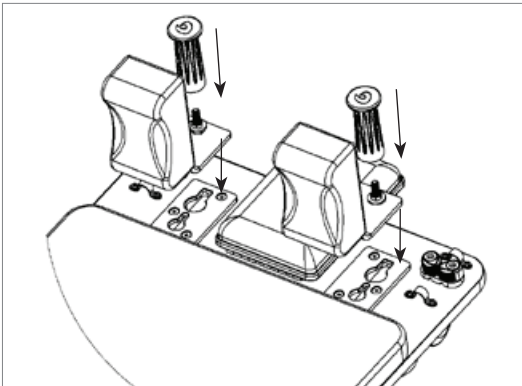

Figure C

INSTALL RISERS

7. Remove the pulleys from your existing risers by loosening the nuts on the back of the risers.
8. Using the provided 5/32" Allen wrench, loosen the middle screw and washer on each riser block and remove them. Slide the riser block down on the riser posts and secure them using

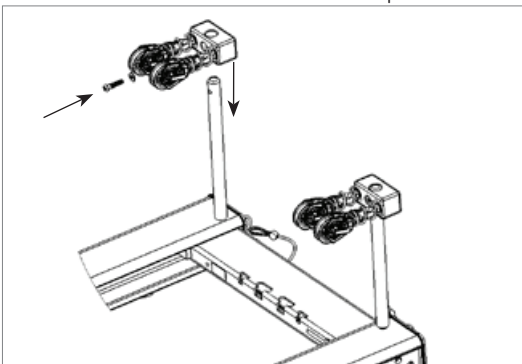

Figure D

the just removed screw and washer. See Figure D. Repeat for the other riser.

INSTALL LOWER PULLEY MOUNTS

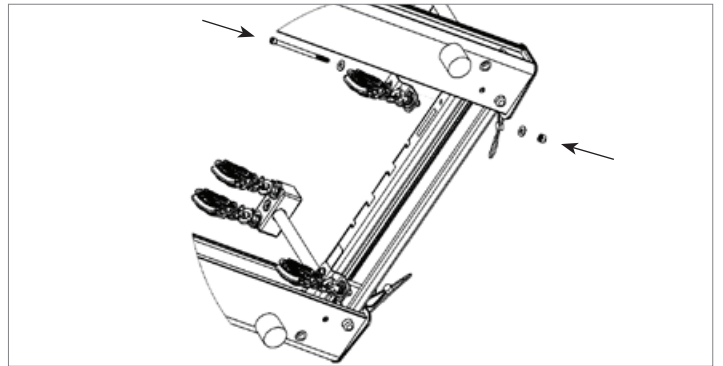

Figure E

9. Install the lower mounts to the inside frame head end cross rail using the 1/4-20 bolts on the inside of the frame, nuts and washers as shown in Figure E.

INSTALL ROPE AND LOOPS

10. Place the black loops with pulleys on the shoulder posts. See Figure F.

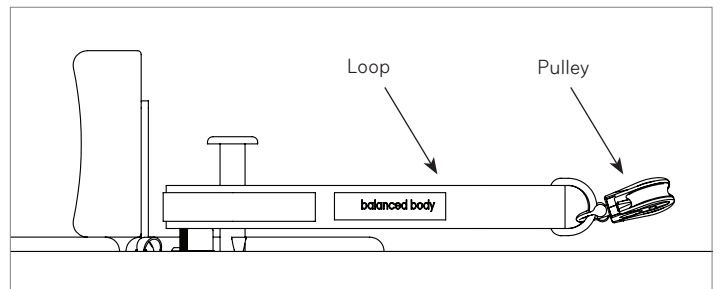

Figure F

11. Thread one end of the rope through both pulleys under the carriage and pull the ends evenly toward the risers. See Figure G.

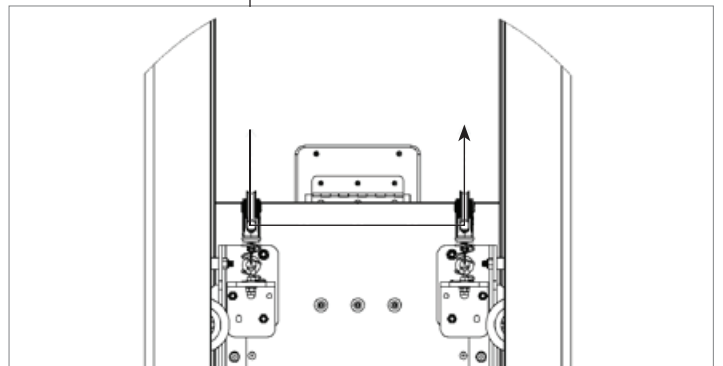

Figure G

12. Take one end of the rope and thread up through the lower mount pulley. Continue threading the rope up through the upper, inner pulley on the riser block and pull toward the carriage. See Figure H.
13. Thread the rope through the pulley attached to the black Tri-Loop with pulley on the same side of the Reformer as the riser and pull back toward the riser. See Figure I.

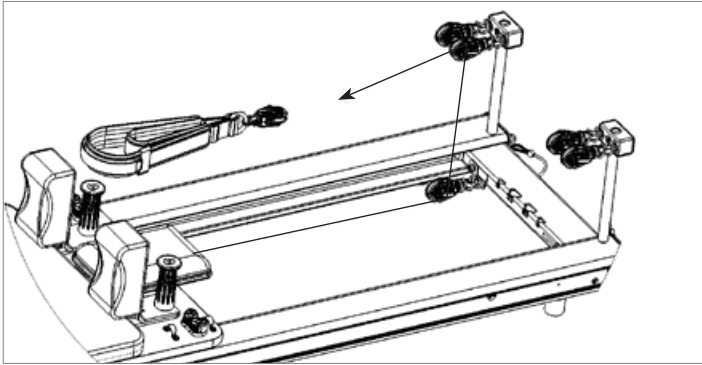

Figure H

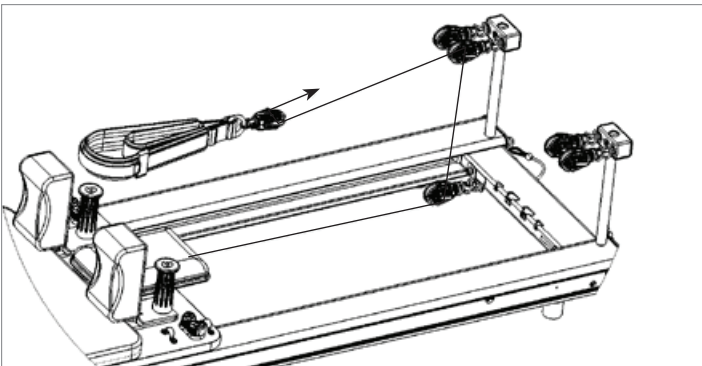

Figure I

14. Thread the rope through the upper, outer pulley on the riser block and pull back toward the carriage. See Figure J. See Figure K for a detailed view of the riser pulley block rope routing.

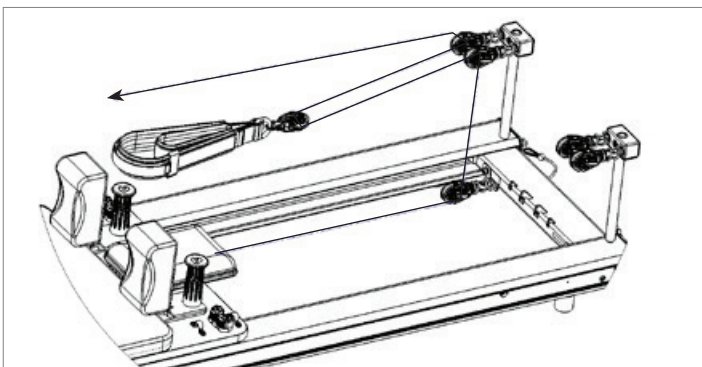

Figure J

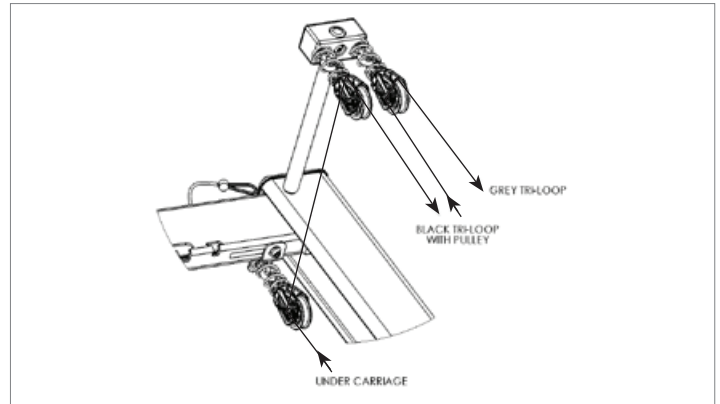

Figure K

15. Using a Soft-Touch connection, see Figure L, secure each end of the rope to a grey Tri-Loop on the same side of the Reformer as the riser.

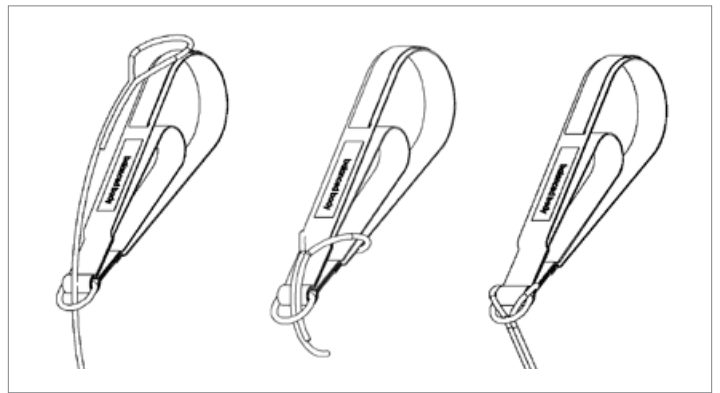

Figure L

16. Repeat steps 12-15 for the other side of the Reformer.

IMPORTANT SAFETY NOTE: Use of the Konnector system in a manner for which it is not intended may result in equipment damage and/or injury to the user. Intense cardio work utilizing jarring movements may overload the system. Balanced Body is not responsible for injuries caused by equipment misuse.

Questions? Call Balanced Body Technical Support at 1-800-PILATES (US and Canada), or +1-916-388-2838 (all other countries).

WARNING: Using the existing shoulder posts with a Konnector system can cause the loops to fall off the posts during use which may cause serious injury.