

Installing the Balanced Body® Konnector™

The Konnector is compatible with Balanced Body Studio Reformers with wooden risers and removable shoulder rests ONLY. If you aren't sure whether this system will work with your equipment, please contact Balanced Body at 1-800-PILATES (US and Canada), or +1-916-388-2838 (all other countries).

To view the installation podcast, please visit www.pilates.com/instructions

TOOLS REQUIRED (NOT INCLUDED):

- » Rag
- » Pipe wrench or vise grips

PARTS LIST (INCLUDED):

ITEM	PART NO.	QTY
Konnector Rope	210-054	1
Konnector Riser Assembly	707-257	2
2-3/4" Allen bolts	GEN8032	4
1/4" Fender washer	GEN9204	4
Tri-Loops (Grey)	210-061	2
Tri-Loops (Black) with pulleys	210-060	2
Flanged shoulder posts	616-188	2
Under Carriage Pulley Bracket	707-258	2
Hair Guard	616-187	1
3/8" Allen bolts	GEN9943	4
1-1/2" Allen bolt	GEN8333	2
1/4" Washer	GEN9952	4
1/4-20 Hex nut	GEN9056	2
1/4-20 Nylock nut	GEN9008	2
Shoulder rest lockdown kit	950-004	1
5/32" Allen wrench	GEN9282	1
3/16" Allen wrench	GEN9280	1
Spare shoulder post bolt	GEN9235	2
Spare shoulder post bolt spacer	GEN9162	2
7/16" Wrench	616-113	1

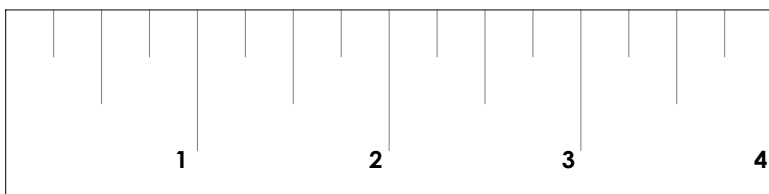

INSTALL FLANGED SHOULDER POSTS

WARNING: Using the existing shoulder posts with a Konnector system can cause the loops to fall off the posts during use which may cause injury.

1. Wrap one shoulder post with a rag to protect it from the teeth on the pipe wrench or vise grips.
2. Tighten or clamp down the pipe wrench or vise grips over the rag and turn counter-clockwise to loosen the shoulder post. Continue unthreading the post by hand and remove completely from the shoulder rest bracket. Repeat on the other post. Set these posts aside, you will no longer need them.

Note: There is no need to remove the entire shoulder rest bracket from the carriage, only the cylindrical shoulder post.

WARNING: Using the existing shoulder posts with a Konnector system can cause the loops to fall off the posts during use which may cause serious injury.

3. Thread the flanged shoulder posts onto the protruding screw. Tighten snugly (Figure A).

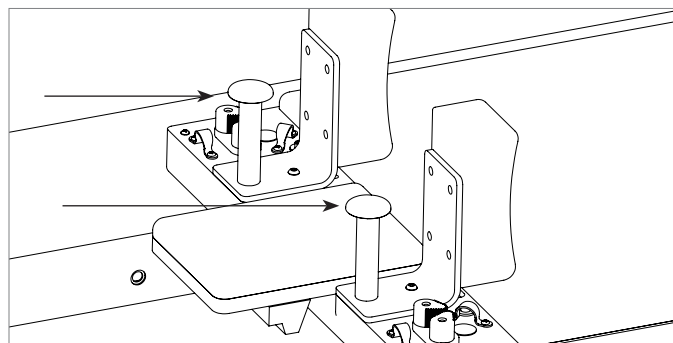

Figure A

WARNING: If you are only using some of the loops, the unused loops MUST be stored on the flanged shoulder posts.

INSTALL THE HAIR GUARD AND CARRIAGE PULLEY BRACKETS

1. Bolt the hair guard to the two carriage pulley brackets using the 3/8" long flanged button head screws. Make sure the threaded holes are facing inward, and the hair guard is aligned as in Figure B. Fully tighten the bolts

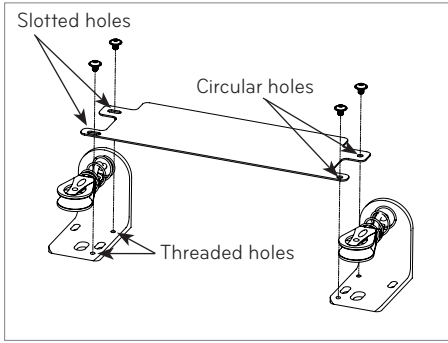

Figure B

that are through the circular holes in the hair guard, and finger-tighten the bolts that are through the slotted holes.

2. Unhook all of the springs from the springbar. Remove the rope from the cam cleats and carriage. Lift the carriage out of the frame, turn it upside down, and rest it across the Reformer frame with the underside facing up.

3. a) If you have a shoulder rest lockdown kit, loosen and remove the black knob on the underside of the carriage (see Figure F, for reference). Set the knob and Allen bolt aside.

b) If you do not have a shoulder rest lockdown kit already installed, remove the silver detent pins. You will need the two 2" Allen bolts and the knurled plastic knobs for the next steps.

4. Align the hair guard and pulley bracket assembly with holes on the underside of the carriage as shown in Figure C. Insert an Allen bolt through the top of the shoulder rest bracket so it protrudes through the pulley bracket on the bottom. Tighten the black knob over the protruding bolt. Make sure the pulleys point toward the headrest. Repeat with the other carriage pulley bracket. See Figure F for a finished view.

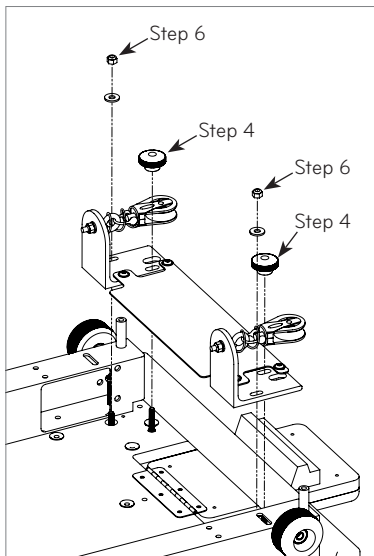

Figure C

5. Find the pre-assembled bolt, washer and nut (Figure D).

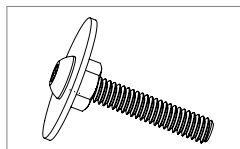

Figure D

6. Put the bolt with washer and nut into the 5/8" hole (where the original rope passed through) from the padded side of the carriage (Figure E). It should slide through a slot in the carriage pulley bracket (refer back to Figure C). Apply a 1/4" washer and nylock nut under the carriage and finger tighten. See Figure F for a finished view.

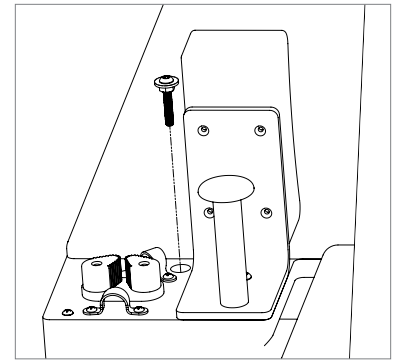

Figure E

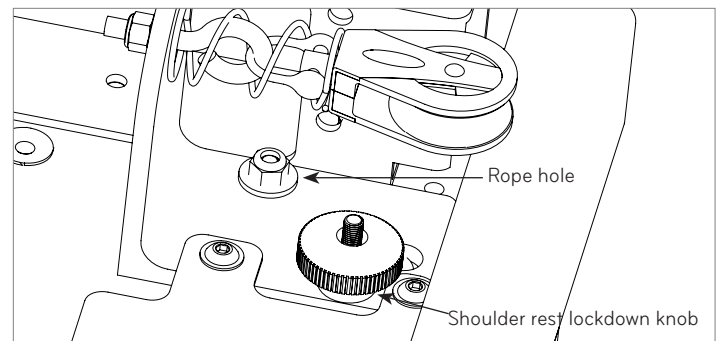

Figure F

7. Repeat steps 5 and 6 for the other carriage pulley bracket.
8. Make sure the front edge of the carriage pulley bracket is flush along the edge of the wooden beam on the carriage. Tighten the black knobs by hand. Tighten the nylock nuts with a wrench (socket wrench, preferred) to secure the brackets in place.
9. Turn the carriage back over onto its wheels and place it on the rails with the headrest toward the risers.
10. Make sure the springbar is in the position closest to the foot end of the reformer ("first gear"). Attach at least one red spring to keep the carriage in place.

INSTALL RISERS

1. Remove the ropes and loops from your Reformer, they are no longer needed.
2. Using the provided 5/32" Allen wrench, loosen the two bolts on each wooden riser and remove them from the frame. Discard the bolts and risers, you will no longer need them.
3. Take the two new wooden risers, Figure G, and install them where the old wooden risers were on the outside of the frame using 1/4" washers, 2-3/4" Allen bolts and the 5/32" Allen wrench (Figure H). Make sure the pulleys face the carriage.

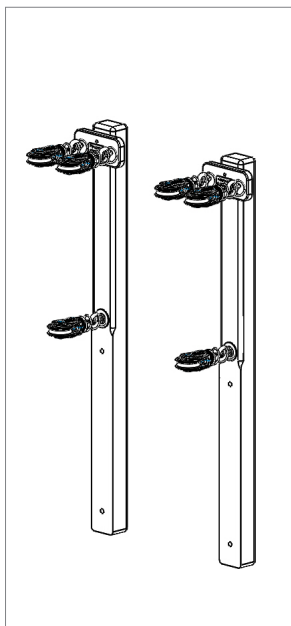

Figure G

3. Take one end of the rope and thread up through the lowest pulley on the riser. Continue threading the rope up through the upper, inner pulley on the riser block and pull toward the carriage (Figure K).

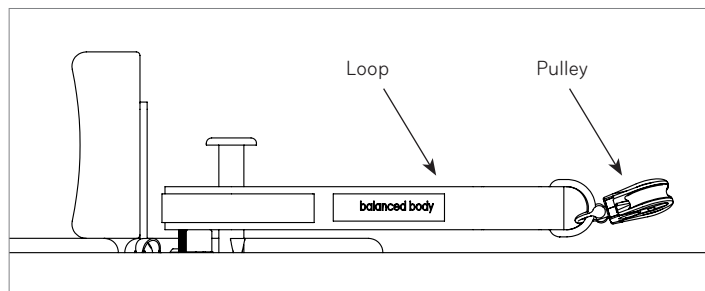

Figure I

4. Thread the rope through the pulley attached to the black Tri-loop with pulley on the same side of the Reformer as the riser and pull back toward the riser (Figure L).

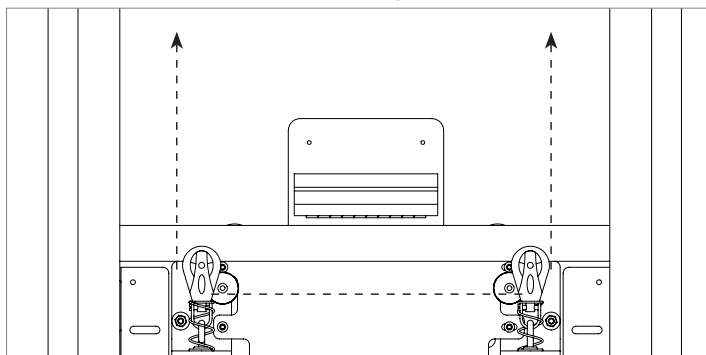

Figure J

5. Thread the rope through the upper, outer pulley on the riser block and pull back toward the carriage (Figure M). See Figure N for a detailed view of the riser pulley block rope routing.

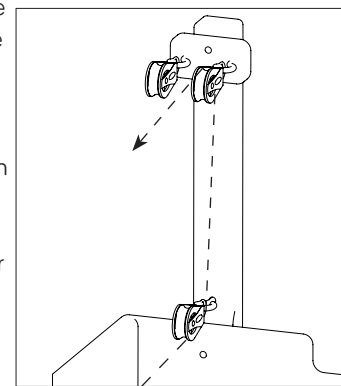

Figure K

6. Using a Soft-Touch connection (Figure O), secure each end of the rope to a grey Tri Loop on the same side of the Reformer as the riser.
7. Repeat steps 2-7 for the other side of the Reformer.

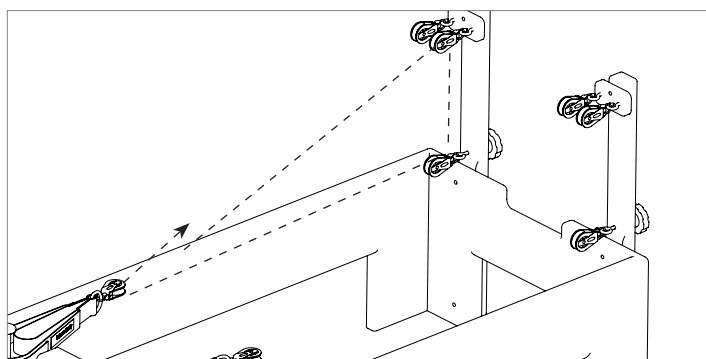

Figure L

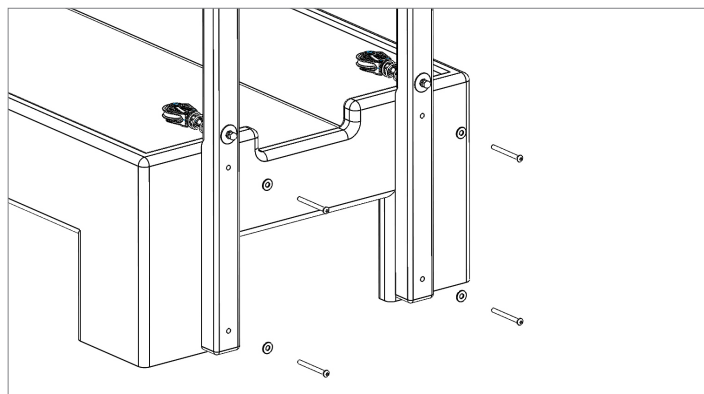

Figure H

INSTALL ROPE AND LOOPS

1. Place the black loops with pulleys on the shoulder posts (Figure I).
2. Thread one end of the rope through both pulleys under the carriage and pull the ends evenly toward the risers (Figure J).

Questions? Call Balanced Body Technical Support at 1-800-PILATES (US and Canada), or +1-916-388-2838 (all other countries).

IMPORTANT SAFETY NOTE: Use of the Konnector system in a

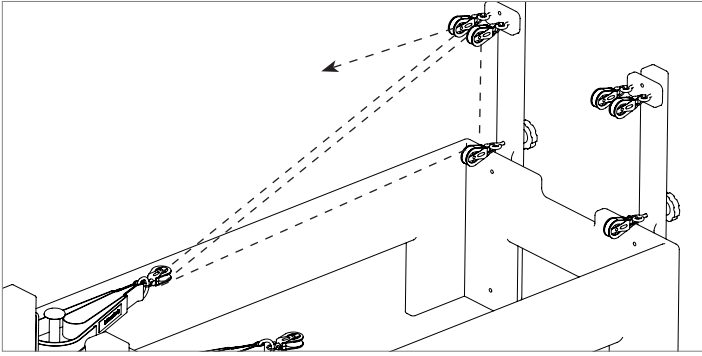

Figure M

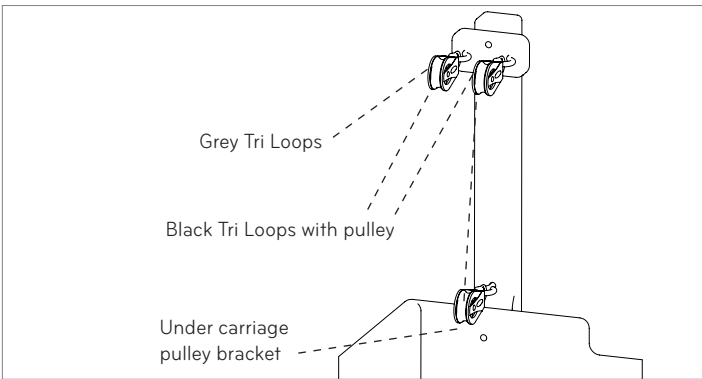

Figure N

manner for which it is not intended may result in equipment damage and/or injury to the user. Intense cardio work utilizing jarring movements may overload the system. Balanced Body is

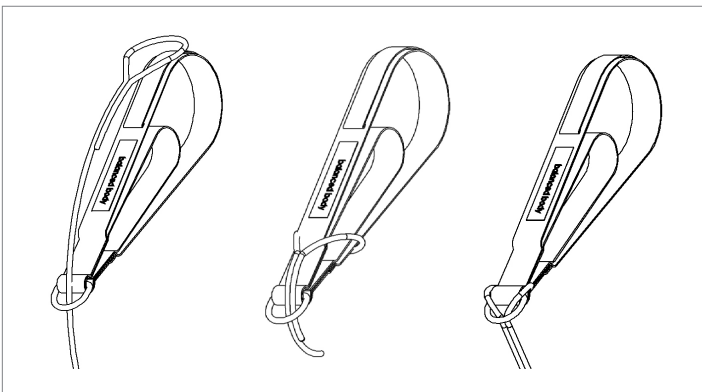

Figure O

not responsible for injuries caused by equipment misuse.